



19706

1/2" Impact Wrench



*Need help with your new Impact Wrench?
Call our customer service hotline at 1-800-386-0191*

SAVE THESE INSTRUCTIONS

IMPORTANT SAFETY PRECAUTIONS

WARNING! Read and understand all instructions before using this tool. Keep this manual for the safety warnings and precautions, operating, inspection and maintenance instructions. When using this tool, basic precautions should always be followed to reduce the risk of personal injury and/or damage to the equipment.

WORK AREA

1. **Keep your work area clean and well lit.** Cluttered and dark areas invite accidents.
2. **Operate in a safe work environment.** Do not use machines or power tools in damp or wet locations. Do not expose to rain. Do not use power tools in the presence of flammable gasses or liquids.
3. **Keep children, bystanders and visitors away from the work area.** Do not let them handle tools, hoses or extension cords. No one should be in the work area if they are not wearing suitable protective equipment.
4. **Store unused equipment.** When not in use, tools must be stored in a dry location to prevent rust. Always lock up tools and keep them out of reach of children.

PERSONAL SAFETY

1. **Use eye, face, head, breathing and ear protection.** Always wear ANSI approved impact safety goggles, which must provide both frontal and side protection. Wear a full face shield if your work creates metal filings or wood chips. Wear an ANSI approved dust mask or respirator when working around metal, wood and chemical dusts and mists. Wear ANSI approved earplugs.
2. **Do not over reach; keep proper footing and balance at all times.** Proper footing and balance enables better control of the tool in unexpected situations.
3. **Dress properly, wear protective equipment.** Do not wear loose clothing or jewelry as they can be caught in moving parts. Tie back long hair. Protective, electrically non-conductive clothes and non-skid footwear are recommended when working.
4. **Stay alert, watch what you are doing and use your common sense.** Do not operate any machine or tool when you are tired, under the influence of drugs, alcohol or medications.
5. **Use clamps or other practical ways to secure and support the work piece to a stable platform.** Holding the work piece by hand or against your body is unstable and may lead to loss of control.

TOOL USE AND CARE

1. **Use the right tool for the job.** Do not attempt to force a small tool or attachment to do the work of a larger industrial tool. The tool will perform better and safer at the task for which it was intended. Do not modify tools or use for a purpose for which they are not designed.
2. **Maintain tools with care.** Keep tools clean, sharp and in good condition for better and safer performance. Follow instructions for lubrication and changing accessories. Inspect tool fittings, alignment and hoses periodically and, if damaged, have them repaired by an authorized technician or replaced. The handles must be kept clean, dry and free from oil and grease at all times. A properly maintained tool reduces the risk of binding and is easier to control. Do not apply excessive force to try to get the job done faster. Applying excessive force can lead to slips and damage to your work or personal injury.
3. **Avoid unintentional starts.** Be sure that the throttle is in neutral or OFF position when not in use and before connecting it to any air source. Do not carry the tool with fingers on or near the switch.
4. **Only use the lubricants supplied with a tool or specified by the manufacturer.** Other lubricants may not be suitable and may damage the tool or even make the tool explode.
5. **When not in use for an extended period, apply a thin coat of lubricant to the steel parts to avoid rust.**
6. **Do not use tool if the trigger switch does not function properly.** Any tool that cannot be controlled with the ON/OFF switch is dangerous and must be repaired.

SERVICE

1. **Check for damaged parts.** Before using any tool, any part that appears to be damaged should be carefully checked to determine that it will operate properly and perform its intended functions. Check for alignment and binding of moving parts, broken parts or mounting fixtures or any other condition that may affect proper operation. Any part that is damaged should be properly repaired or replaced by qualified technician.
2. **When servicing, use only identical replacement parts.** Only use accessories intended for use with this tool. Replace damaged parts immediately.

AIR SOURCE

1. **Disconnect air supply.** Disconnect tools from air pressure source when not in use, before cleaning, servicing or changing a piece or accessory. After disconnecting, discharge any residual air pressure.
2. **Use proper size and type of air pressure line and fittings.** The recommended air line for this tool is 1/4" NPT air inlet.
3. **Always verify prior to using a tool that the air source has been adjusted to the rated air pressure or within the rated air pressure range.** Over-pressurizing a tool may cause bursting, abnormal operation, breakage of the tool or serious injury to persons. Use only clean, dry, regulated air at the rated pressure as marked on the tool.
4. **Never use pure oxygen, carbon dioxide, combustible gases or any bottled gas as an air source for a tool.** Such gases are capable of causing an explosion and serious injury to persons. Do not use an air source other than an air compressor to power this tool.
5. **Always use an air regulator and a moisture trap in your compressed air system.**
6. **Drain the air tank daily.** Water in the air line will damage the tool.
7. **Clean air inlet filter weekly.**
8. **Avoid using an unnecessarily long air hose.** Choose a hose that is appropriate for the situation, as a hose that is too long and running across the floor can be more dangerous than helpful.
9. **Keep hose away from heat, oil and sharp edges.** Check hose for wear, and make certain that all connections are secure.
10. **Always carry a tool by its handle, never carry the tool by the air hose.**
11. **Line pressure should be increased to compensate for unusually long air hoses over 25 feet. (8 meters).** The hose diameter should be 3/8" I.D.

VIBRATION PRECAUTIONS

Some tools vibrate during use. Repeated or long-term exposure to vibration may cause temporary or permanent physical injury, particularly to the hands, arms and shoulders.

1. **Anyone using vibrating tools regularly or for an extended period should first be examined by a doctor and then have regular medical checkups to ensure medical problems are not being caused by or worsened from tool use.** Pregnant women or people who have impaired blood circulation to the hands, past hand injuries, nervous system disorders, diabetes or Raynaud's Disease should not use these tools. If you feel any medical symptoms related to vibrations (such as tingling, numbness, and white or blue fingers), seek medical attention as soon as possible.
2. **Do not smoke during use.** Nicotine reduces the blood flow to the hands and fingers, increasing the risk of vibration-related injury.
3. **Wear suitable gloves to reduce the vibration effects on the user.**
4. **Use tools with the lowest amount of vibration when there is a choice between different processes.**
5. **Do not use for extended periods.** Take frequent breaks when using these tools.
6. **Let the tool do the work.** Grip tool as lightly as possible (while still keeping safe control of it.)
7. **To reduce vibration, maintain tool as explained in this manual.** If abnormal vibrations occur, stop using this tool immediately.

LUBRICATION

An automatic inline filter-regulator-lubricator is recommended as it increases tool life and keeps the tool in sustained operation. The inline lubricator should be regularly checked and filled with air tool oil. Proper adjustment of the inline lubricator is performed by placing a sheet of paper next to the exhaust ports and holding the throttle open for approximately 30 seconds. The lubricator is properly set when a light stain of oil collects on the paper. Excessive amounts of oil should be avoided.

In the event that it becomes necessary to store the tool for an extended period of time (overnight, weekend, etc.), it should receive a generous amount of lubrication at that time. The tool should be run for approximately 30 seconds to ensure oil has been evenly distributed throughout the tool. The tool should be stored in a clean and dry environment.

- **It is most important that the tool be properly lubricated by keeping the inline lubricator filled and correctly adjusted.** Without proper lubrication the tool will not work properly and parts will wear prematurely.
- **Use the proper lubricant in the inline lubricator.** The lubricator should be of low air now or changing air now type and should be kept filled to the correct level. Use only recommended lubricants, specially made for pneumatic applications. Substitutes may harm the rubber compounds in the tool's O-rings and other rubber parts.

USER-MAINTENANCE INSTRUCTIONS

If a filter/regulator/lubricator is not installed on the air system, air operated tools should be lubricated at least once a day or after 2 hours work with 2 to 6 drops of oil, depending on the work environment, directly through the male fitting in the tool housing. Only a qualified technician should perform procedures not specifically explained in this manual.

1. **Incorporate an in-line oiler, shut-off valve, regulator with pressure gauge, and filter for best service, as shown in the diagram at right.** An inline shutoff valve is an important safety device because it controls the air supply even if the air hose is ruptured.

Note:

If an automatic oiler system is not used, add a few drops of pneumatic tool oil to the airline connection before operation. Add a few more drops after each hour of continuous use.

2. **Attach an air hose to the compressor's air outlet.**
Connect the air hose to the air inlet of the tool.

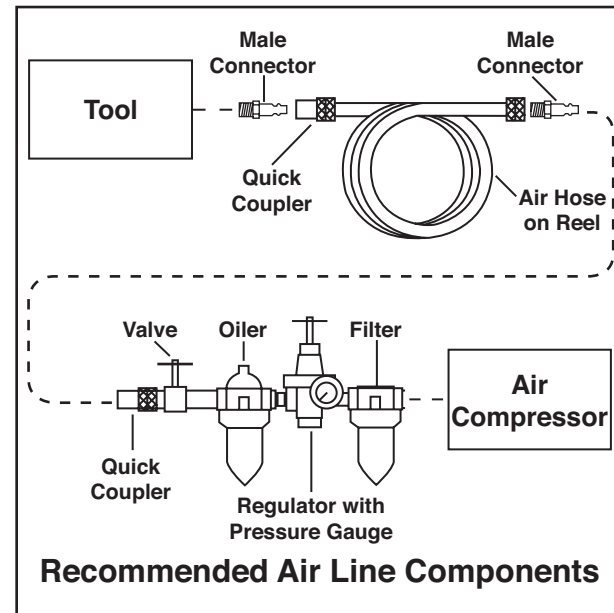

INSTALLATION

1. **Attach a standard 1/4" air connector to the tool's air inlet.** Wrap the threaded portion of the air connector with Teflon tape. Tighten securely.
2. **Attach a standard quick-connector to the air pressure source hose.** Attach the air hose to the tool.
3. **Set the air pressure regulator on the air compressor to 90 PSI.**



WARNING Do not exceed the recommended pressure of 90 PSI. Excess pressure could result in damage to the tool, to your work piece or serious injury.

4. **Check the air line and its connections for air leaks.** Do not use this tool until you have repaired all air leaks.

Note:

Turn off the air compressor, disconnect the air pressure hose and discharge any residual pressure before changing accessories or making any adjustments to the tool. Failure to do so could result in severe injury or property damage.

TECHNICAL DATA

Square drive:	1/2"
Bolt size:	5/8" (16mm)
Free running speed:	7,000 RPM
Max torque:	230 ft/lbs (310 N.m)
Avg. air consumption:	5-10 CFM (142-283 l/min)
Suggested air pressure:	90 PSI (6.3 bar)
Air inlet size:	1/4" NPT
Air hose:	3/8" I.D.
Suggested air compressor:	2 HP



DESCRIPTION

Die cast aluminum body, Reversible, Rubber scuff guards on nose and back, Built-in air regulator varies speed & power, front exhaust, designed for removing and installing nuts and bolts. Also ideal for tire changing and general assembling work and other workshop applications.

OPERATION

1. **Only use impact sockets which are specifically designed for use with air impact wrenches.**
2. **Connect the wrench to the air hose as described on previous page.**
3. **Place the socket over the subject nut and depress the trigger to operate the wrench.**
4. **To change direction push the button at the top of the handle. Push "R" for reverse and "F" for forward**
5. **The flow of air may be regulated by adjusting flow valve at the base of the handle.**



WARNING DO NOT use any additional force upon the wrench in order to remove a nut. DO NOT allow wrench to free run for an extended period of time as this will shorten its life.

MAINTENANCE

Disconnect tool from air supply before changing accessories, servicing or performing maintenance. Replace or repair damaged parts immediately.

1. **Lubricate the tool daily by dropping a few drops of air tool oil into the air inlet, or use an in-line oiler as described on Page 4.**
2. **Clean the tool after use.**

Parts Breakdown

#	Description	#	Description	#	Description	#	Description
1	Protecting Rubber	13	Oil seal	25	Protecting Rubber	37	Air Regulator
2	Housing	14	Front End plate	26	Valve Sleeve	38	Bolt
3	Bolt	15	Rotor blade	27	Reverse Valve	39	Pin
4	Anvil Bushing	16	Rotor	28	O-ring	40	Trigger
5	Anvil Collar	17	Pin	29	Valve Stem	41	Exhaust cover
6	O-ring	18	Cylinder	30	Washer	42	Bolt
7	Anvil	19	Bolt	31	Steel ball	43	Screw
8	Hammer Pin	20	Rear End Plate	32	Inlet Spring	44	Spring
9	Hammer Cage	21	Gasket	33	Air Inlet Plug	45	Pin
10	Hammer Dog	22	Rear Cover	34	Dust Free Cover		
11	Drive Cam	23	Washer	35	Spring		
12	Ball Bearing	24	Bolt	36	O-ring		

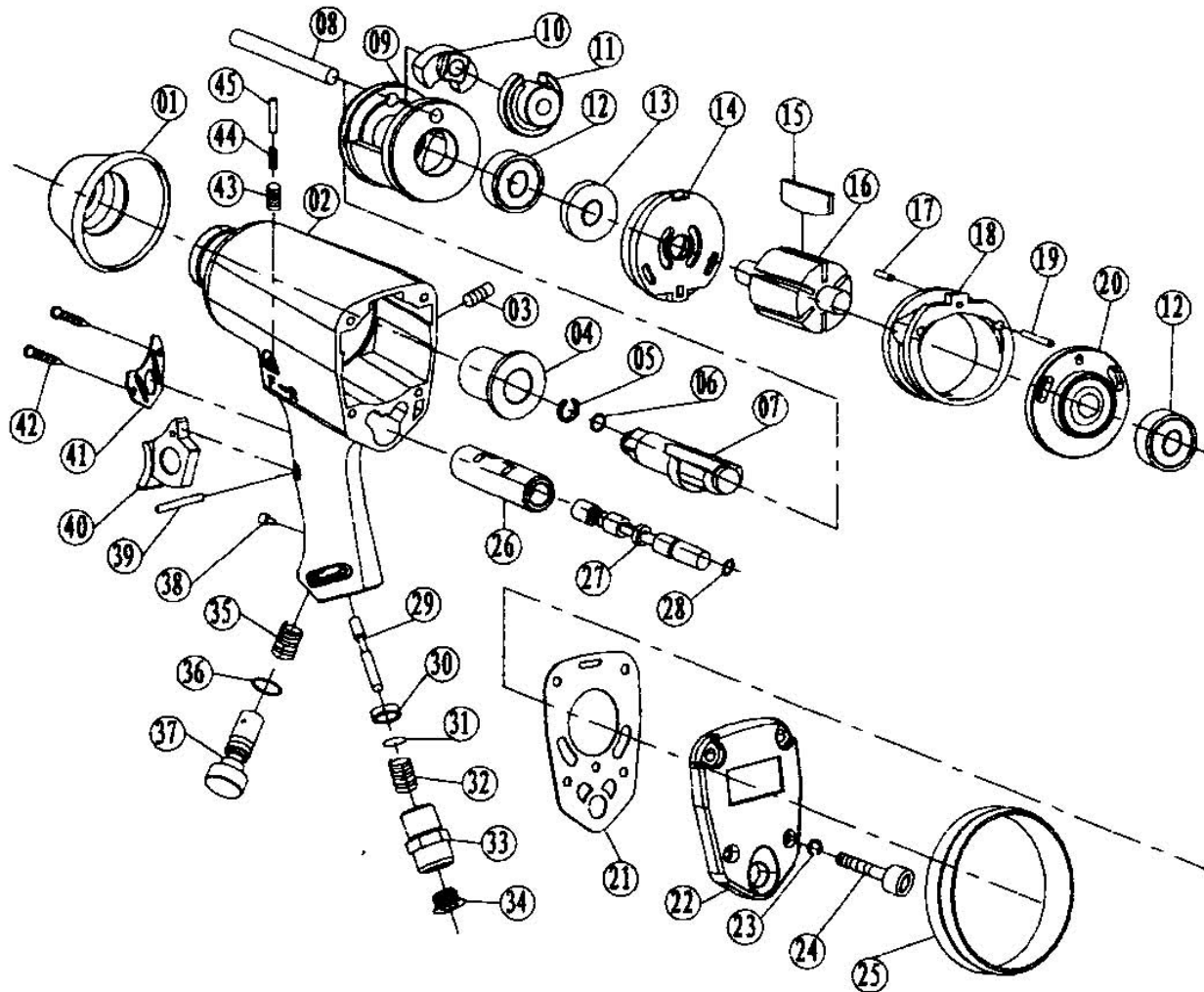

TROUBLESHOOTING

Problem	Possible Cause	Suggested Solutions
Tool runs at normal speed but loses power under load	Motor parts worn Cam clutch worn or sticking due to lack of lubricant	Have a qualified technician replace worn parts 1. Lubricate clutch housing. 2. Check for excess clutch oil. 3. Overfilling can cause drag on high speed clutch parts, ie, a typical oiled/lubricated wrench requires 1/2 oz. of oil. Grease lubricated note: Heat usually indicates insufficient grease in chamber, Severe operating conditions may require more frequent lubrication.
Tool runs slowly. Air flows slightly from exhaust.	Motor parts jammed with dirt particles. Power regulator in closed position. Air flow blocked by dirt.	1. Check air inlet filter for blockage. 2. Pour air tool lubricating oil into air inlet as per instructions. 3. Operate tool in short bursts quickly reversing rotation back and forth where applicable. 4. Repeat above as needed. If this fails, return to service center.
Tool will not run. Air flows freely from exhaust.	O-rings throttle valve dislodged from seat inlet valve.	1. Pour air tool lubricating oil into air inlet as per instructions. 2. Operate tool in short bursts of forward and/or reversing rotation where applicable. 3. Tap motor housing gently with plastic mallet. 4. Disconnect supply. Free motor by rotating drive shank manually where applicable. 5. If tool remains jammed, return to service center.
Tool will not shut off.	O-rings throttle valve dislodged from seat inlet valve.	Have a qualified technician replace the O-ring
Loss of power or erratic performance.	Excessive drain on the air line. Moisture or restriction in the air pipe. Incorrect size or type of hose connectors.	Check the air supply. If tool is not connected to a 1/4" line, connect it properly.
Note: Repairs should be carried out by a qualified person.		

Distributed by Star Asia-USA, LLC
P.O. Box 58399, Renton, WA 98058
Consumer Service: 800-386-0191
e-mail: info@titan-us.com
©2010 Star Asia-USA, LLC